

**Name : Dr. Sanjib Pramanik**

**Name of the College : Durga College, Raipur (C.G.), India**

**Name of the Faculty : Arts**

**Designation : Assistant Professor, Department of Geography**

**Topic : SURVEYING BY THEODOLITE**

**Date : 15/09/2025**

# Definition

- A transit theodolite is one in which the telescope revolution about its horizontal axis in a vertical plane.
- The system of surveying in which the angles are measured with the help of a theodolite, is called Theodolite Surveying.



# Introduction

- Theodolite is a basic surveying instrument which is use for measuring vertical and horizontal angle.
- Theodolite is more precise than magnetic compass.
- Magnetic compass measures the angle up to accuracy of 30'.
- However a vernier Theodolite measures the angles up to accuracy of 10", and 20".

# History of Theodolit

- The term *diopter* was sometimes used in old texts as a synonym for theodolite.
- This derives from an older astronomical instrument called a dioptra.
- Prior to the theodolite, instruments such as the groma, geometric square and various other graduated circles (see circumferentor) and semicircles (see graphometer) were used to obtain either vertical or horizontal angle measurements.
- It was only a matter of time before someone put two measuring devices into a single instrument that could measure both angles simultaneously.
- Gregorius Reisch showed such an instrument in the appendix of his book *Margarita Philosophica*, which he published in Strasburg in 1512.
- It was described in the appendix by Martin Waldseemüller, a German topographer and cartographer, who made the device in the same year. Waldseemüller called his instrument the *polimetrum*.
- The first occurrence of the word "theodolite" is found in the surveying textbook *A geometric practice named Pantometria* (1571) by Leonard Digges, which was published posthumously by his son, Thomas Digges.

# Classification of Theodolites

```
graph TD; A[Classification of Theodolites] --> B[Base on Horizontal Axis]; A --> C[Base on Angle]; B --> D[Transit Theodolite]; B --> E[Non-Transit Theodolite]; C --> F[Vernier Theodolite]; C --> G[Micrometer Theodolite]; C --> H[Electronic digital Theodolite];
```

Base on  
Horizontal  
Axis

Base on  
Angle

Transit  
Theodolite

Non-Transit  
Theodolite

Vernier  
Theodolite

Micrometer  
Theodolite

Electronic  
digital  
Theodolite

## A. Base on Horizontal Axis

### Transit Theodolite

- A theodolite is called a transit theodolite when its telescope can be transited i.e. revolved through a complete revolution about its horizontal axis in the vertical plane.

### Non-Transit Theodolite

- The telescope cannot be transited. They are inferior in unity and have now become obsolete.

## B. Base on Angle

### Vernier Theodolite

- For reading the graduated circle if verniers are used, the theodolite is called as a Vernier Theodolite.

### Micrometer Theodolite

- Whereas, if a micrometer is provided to read the graduated circle the same is called as a Micrometer Theodolite.

### Electronic Theodolite      Digital

- Reading directly providing as digital number if electronic distance measuring is attached with it then it's call total station.

# Uses of Theodolite

The Theodolite is a most accurate surveying instrument mainly used for:

1. Measuring horizontal and vertical angles
2. Locating points on a line
3. Prolonging survey lines
4. Finding difference of level
5. Setting out grades
6. Ranging curves
7. Tacheometric survey

# Essential Equipments for Theodolite Surveying

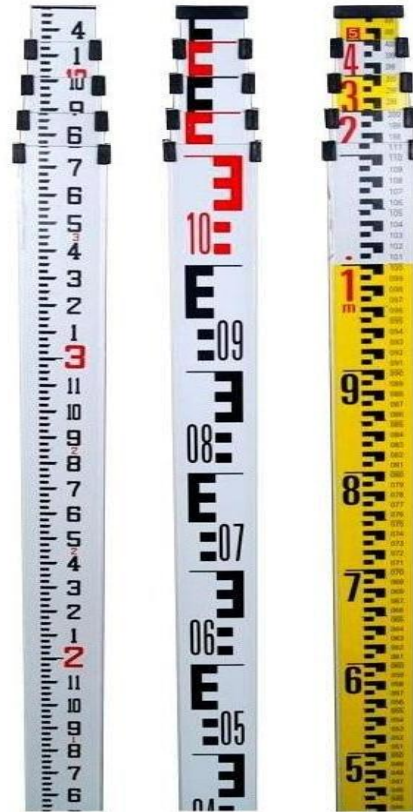

- Theodolite
- Levelling Staff
- Pegs
- Plumb bob

# Description of a Transit Vernier Theodolite

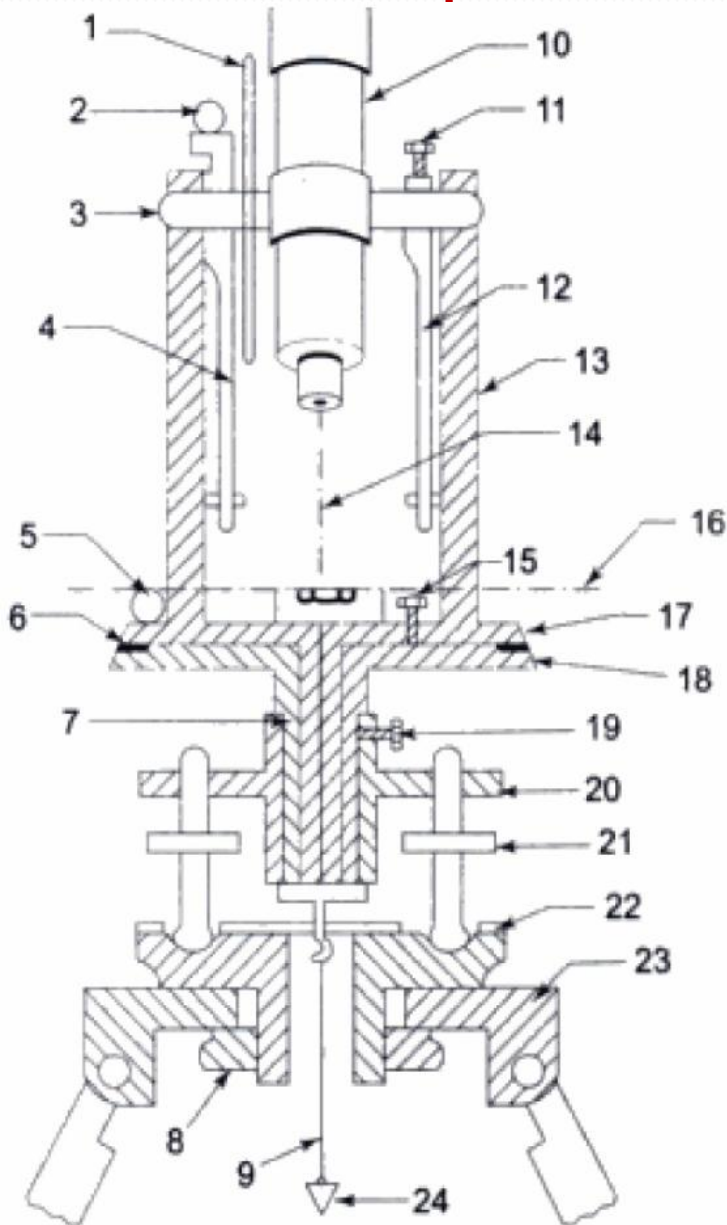

1. Vertical Circle
2. Altitude Bubble
3. Horizontal Axis
4. Vernier Arm
5. Plate Bubble
6. Graduated Arc
7. Levelling Bead
8. Clamping Nut
9. Vertical Axis
10. Telescope
11. Vertical Circle
12. Arm of the vertical circle clam
13. Standard
14. Line of Sight
15. Upper plate clamping screw
16. Axis of plate bubble
17. Upper plate
18. Lower plate
19. Lower plate clamping screw
20. Tribrach
21. Foot screw
22. Trivet
23. Tripod top
24. Plumb bob

# Method of Reading Vernier

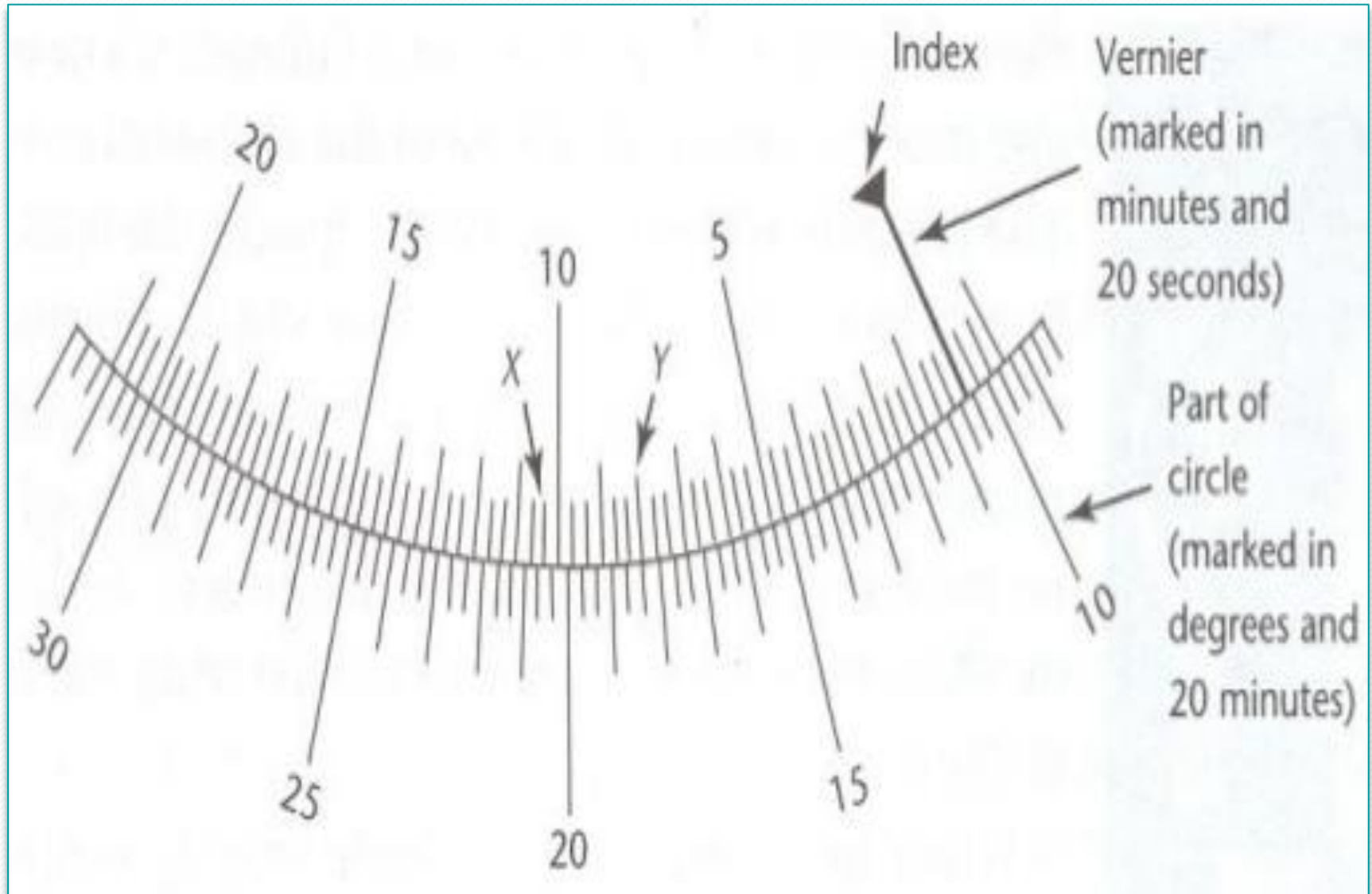

# Terms used in Manipulating a Transit Vernier Theodolite

## 1. Centering

- Centering means setting the theodolite exactly over an instrument-station so that its vertical axis line immediately above the station-mark. It can be done by means of plumb bob suspended from a small hook attached to the vertical axis of the theodolite.

## 2. Transiting

- Transiting is also known as plunging or reversing. It is the process of turning the telescope about its horizontal axis through  $180^\circ$  in the vertical plane thus bringing it upside down and making it point, exactly in opposite direction.

## 3. Swinging the telescope

- It means turning the telescope about its vertical axis in the horizontal plane. A swing is called right or left according as the telescope is rotated clockwise or counter clockwise.

## 4. Face Left

- If the vertical circle of the instrument is on the left side of the observer while taking a reading, the position is called the face left and the observation taken on the horizontal or vertical circle in this position is known as the face left observation.

## 5. Face Right

- If the vertical circle of the instrument is on the right side of the observer while taking a reading, the position is called face right and the observation taken on the horizontal or vertical circle in this position is known as the face right observation.

## 6. Changing Face

- It is the operation of bringing the vertical circle to the right of the observer, if originally it is to the left and vice-versa.

## 7. Line of Collimation

- It is also known as the line of sight. It is an imaginary line joining the intersection of the cross-hairs of the diaphragm to the optical centre of the object-glass and its continuation

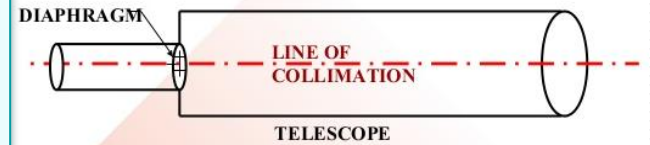

## 8. Axis of the Telescope

- It is also known as an imaginary line joining the optical centre of the object-glass to the centre of eye piece.

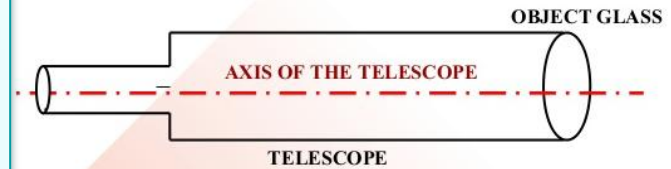

### 9. Axis of the Level Tube

- It is also called the bubble line.
- It is straight line tangential to the longitudinal curve of the level tube at the centre of the tube. It is horizontal when the bubble is in the centre.

### 10. Vertical Axis

- It is the axis about which the telescope can be rotated in the horizontal plane.

### 11. Horizontal Axis

- It is the axis about which the telescope can be rotated in the vertical plane. It is also called the trunion axis.

# Adjustment of a Theodolite

## Temporary Adjustment

The temporary adjustments are made at each set up of the instrument before we start taking observations with the instrument. There are three temporary adjustments of a theodolite:-

Setting and Centering

Levelling

Elimination of Parallax

# Procedure

1. Setup the instrument at station P.
2. Perform all temporary adjustments.
3. Bring the line of collimation horizontal
4. Entire the initial readings in the tabular form
5. Swing the telescope and take staff reading over the given B.M.
6. Swing the telescope towards the object

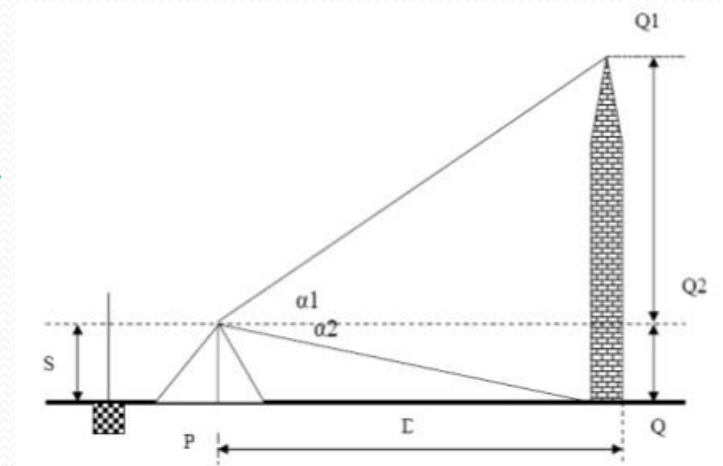

# Measurement of Horizontal Angles:-

There are three methods of measuring horizontal angle:-

General Method

Repetition Method

Reiteration Method

# General Method

Contd.....

To measure horizontal angle of AOB:-

- i. Set up the theodolite at station point O and level it accurately.
- ii. Set the vernier A to the zero or  $360^\circ$  of the horizontal circle. Tighten the upper clamp.
- iii. Loosen the lower clamp. Turn the instrument and direct the telescope towards A to bisect it accurately with the use of tangent screw. After bisecting accurately check the reading which must still read zero. Read the vernier B and record both the readings.
- iv. Loosen the upper clamp and turn the telescope clockwise until line of sight bisects point B on the right hand side. Then tighten the upper clamp and bisect it accurately by turning its tangent screw.
- v. Read both verniers. The reading of the vernier, which was initially set at zero gives the value of the angle AOB directly and that of the other vernier B by deducting  $180^\circ$ . The mean of the two vernier reading gives the value of the required angle AOB.
- vi. Change the face of the instrument and repeat the whole process. The mean of the vernier readings gives the second value of the angle AOB which should be approximately or exactly equal to the previous value.
- vii. The mean of the two values of the angle with face right gives the required angle free from all instrumental errors.

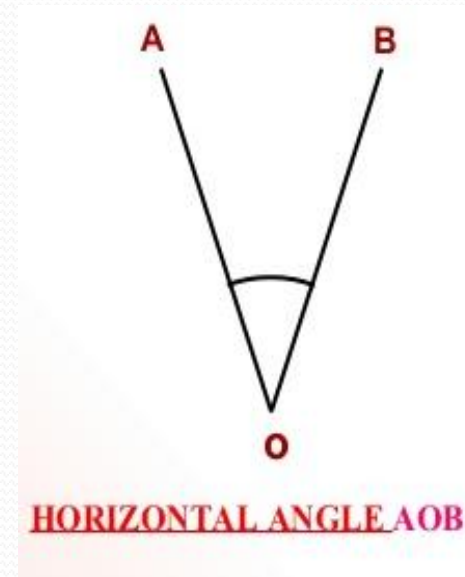

# Theory of Stadia Tachometry

$A_1, A_2, C$  = readings on staff cut by three hairs

$a_1, a_2, C$  = bottom, top and central hairs of diaphragm

$a_1, a_2 = i$  = length of image

$A_1 A_2 = s$  = staff intercept

$F$  = focus

$V$  = vertical axis of instrument

$f$  = focal length of object glass

$d$  = distance between optical centre and vertical axis of instrument

$u$  = distance between optical centre and staff

$v$  = distance between optical centre and image

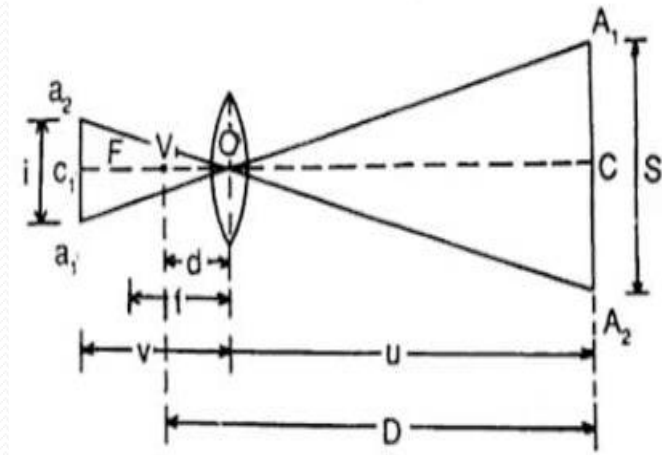

# Exercises

## Base Accessible Method

### THEODOLITE SURVEY

Place: Durga Mahavidyalaya

Date: 20.04.17

Time: 9.30 am.

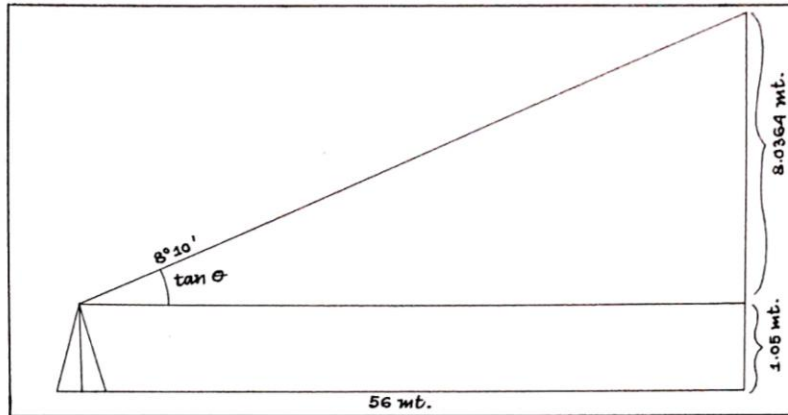

Step-1

The different between instrument and object =  $D$

$$D = S \times f + \frac{f}{\theta}$$

$$= (1.160 \text{ mt} - 0.600 \text{ mt}) \times 100 + 0$$

$$= 0.56 \text{ mt.} \times 100 + 0$$

$$= 56 \text{ mt.}$$

$\therefore$  Where,  
 $S$  = Difference between upper and lower stadia  
 $f$  = Constant (100)

Step-2

Height of the object above the instrument =  $h$

$$h = D \times \tan \theta$$

$$= 56 \text{ mt} \times \tan 8^\circ 10'$$

$$= 56 \text{ mt.} \times 0.1435$$

$$= 8.0364 \text{ mt.}$$

Step-3

Height of the object above the ground level,  $H$

$$H = h + S$$

$$= 8.036 \text{ mt.} + 1.050 \text{ mt.}$$

$$= 9.086 \text{ mt.}$$

So, The height of the object above the ground surface is 9.0864 mt.

# Base Inaccessible Method

Contd.....

**THEODOLITE SURVEY**  
BASE INACCESSIBLE METHOD  
UNIVERSITY COMPOUS

Instruments	Reading on B.M	Angle of elevation	Staff Reading			REMARK
			U.S	M.S	L.S	
A	1.040	12°16'20"	1.475	1.420	1.365	B.M = 289.260 mt
B	0.935	10°42'20"				

Step-I  
Horizontal distance between station A and B  
 $A \text{ and } B = f/i \times S + (f+d)$   
 $= 100 \times (U.S - L.S)$   
 $= 100 \times 0.11 = 11 \text{ mt}$

Step-II  
Distance from station A to the object of the base D  
 $= \frac{(b - hd \cot \theta_2) \tan \theta_1}{\tan \theta_1 - \tan \theta_2}$   
 $= \frac{(11 - 0.105 \times \cot 10^\circ 42' 20'') \tan 12^\circ 16' 20''}{\tan 12^\circ 16' 20'' - \tan 10^\circ 42' 20''}$   
 $= \frac{10.9446 - 0.18905}{0.21752 - 0.18905}$   
 $= \frac{1.97455}{0.02847} = 6.9 \text{ mt}$

Step-III  
Height of the top of the building of the axial line of  
 $h_1 = \frac{(b - hd \cot \theta_2) \tan \theta_1 \tan \theta_2}{\tan \theta_1 - \tan \theta_2}$   
 $= \frac{(11 - 0.15 \times 5.28953) \times 0.21752 \times 0.18905}{0.21752 - 0.18905}$   
 $= \frac{0.42948}{0.02847} = 15.08 \text{ mt}$

Step-IV  
Height of the building from ground (H) =  $(h_1 + h_2) \text{ mt}$   
 $= (15.08 + 1.040) \text{ mt}$   
 $= 16.12 \text{ mt}$

Step-V Height of the building from the sea level =  $(H + B.M)$   
 $= (16.12 + 289.260) \text{ mt}$   
 $= 305.38 \text{ mt}$



THANK YOU!